

ES89Ax(-S) Series On/Off Electric Spring Return Actuators

Installation Instructions

Part No. 34-636-1980, Rev. —
Issued September 18, 2006

Applications

The ES89Ax(-S) Series On/Off Electric Spring Return Actuators are direct-mount, spring return electric actuators that operate on AC 24 V power at 50/60 Hz, or on DC 24 V power or AC 120 V power at 60 Hz. These bidirectional actuators do not require a damper linkage and are easily installed on dampers with 1/2 to 3/4 in. or 12 to 19 mm round shafts, or 3/8 and 1/2 in. or 10, 12, and 14 mm square shafts using the standard shaft clamp included with the actuator. An optional M9220-600 Jackshaft Coupler Kit is available for 3/4 to 1-1/16 in. or 19 to 27 mm round shafts, or 5/8 and 3/4 in. or 16, 18, and 19 mm square shafts.

The ES89Ax(-S) Series On/Off Electric Spring Return Actuators provide a running and spring return torque of 89 lb-in (10 N·m). Integral line voltage auxiliary switches are available on the ES89Ax-S Series models to indicate end-stop position or to perform switching functions within the selected rotation range.

IMPORTANT: Use this ES89Ax(-S) Series On/Off Electric Spring Return Actuator only to control equipment under normal operating conditions. Where failure or malfunction of the electric actuator could lead to personal injury or property damage to the controlled equipment or other property, additional precautions must be designed into the control system. Incorporate and maintain other devices such as supervisory or alarm systems or safety or limit controls intended to warn of, or protect against, failure or malfunction of the electric actuator.

Installation

The ES89Ax(-S) Series On/Off Electric Spring Return Actuators mount directly to the surface in any convenient orientation using two M3 x 9.5 mm self-drilling sheet metal screws and the anti-rotation bracket (parts included with the actuator). No additional linkages or couplers are required. Electrical connections are color-coded and identified with numbers permanently marked on the actuator cable. A tag on the actuator cable identifies the electrical connections, and wiring details are also included on the actuator housing.

IMPORTANT: Do not install or use this ES89Ax(-S) Series On/Off Electric Spring Return Actuator in or near environments where corrosive substances or vapors could be present. Exposure of the electric actuator to corrosive environments may damage the internal components of the device, and will void the warranty.

Parts Included

- on/off electric spring return actuator with coupler
- anti-rotation bracket
- manual override crank
- two M3 x 9.5 mm self-drilling sheet metal mounting screws
- two No. 10-32 x 9/16 in. thread-forming conduit screws

Special Tools Needed

- torque wrench with 3/8 in. (10 mm) socket
- digital voltmeter or M9000-200 Commissioning Tool

Dimensions

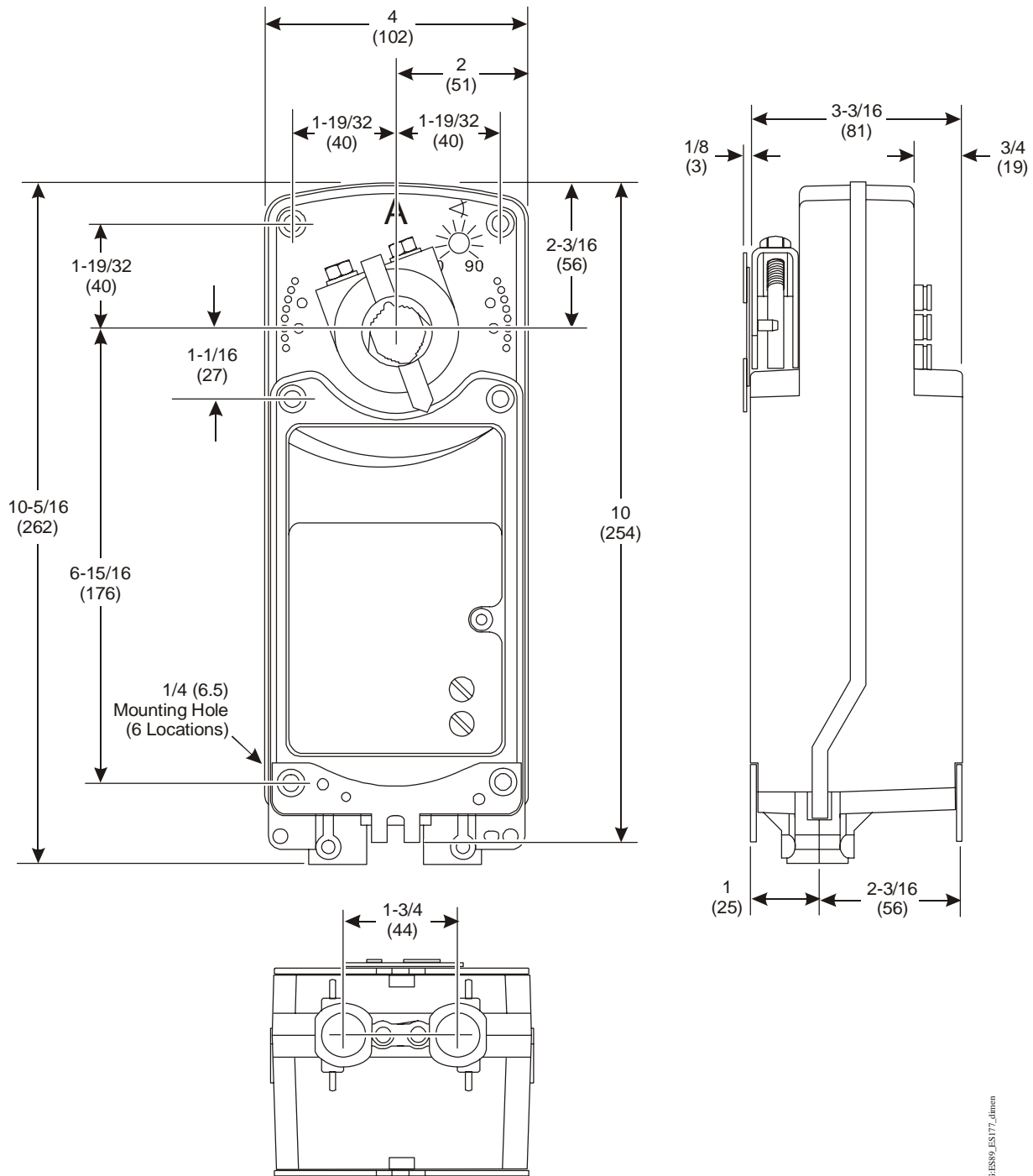

FIG:ES89A_ES177.dimen

Figure 1: ES89Ax(-S) Series On/Off Electric Spring Return Actuator Dimensions, in. (mm)

Accessories

Table 1: Accessories and Replacement Parts (Order Separately)

Code Number	Description
DMPR-KC003¹	7 in. (178 mm) Blade Pin Extension (without Bracket) for Direct-Mount Damper Applications
M9000-153	Crank Arm
M9000-170	Remote Mounting Kit, Horizontal. Kit includes Mounting Bracket, M9000-153 Crank Arm, Ball Joint, and Mounting Bolts.
M9000-171	Remote Mounting Kit, Vertical. Kit includes Mounting Bracket, M9000-153 Crank Arm, Ball Joint, and Mounting Bolts.
M9000-200	Commissioning Tool that Provides a Control Signal to Drive 24 V On/Off, Floating, Proportional, and/or Resistive Electric Actuators
M9000-320	Weather Shield Enclosure - NEMA 3R enclosure for protecting a single ES89/177 Series Actuator from rain, sleet, or snow.
M9000-604	Replacement Anti-Rotation Bracket Kit (with Screws) for ES89/177 Series Floating Electric Spring Return Actuators
M9220-600	1 in. (25 mm) Jackshaft Coupler Kit (with Locking Clip) for Mounting ES89/177 Series Floating Electric Spring Return Actuators on Dampers with 3/4 to 1-1/16 in. or 19 to 27 mm Round Shafts, or 5/8 and 3/4 in. or 16, 18, and 19 mm Square Shafts
M9220-601	Replacement Coupler Kit (with Locking Clip) for Mounting ES89/177 Series Floating Electric Spring Return Actuators on Dampers with 1/2 to 3/4 in. or 12 to 19 mm Round Shafts, or 3/8 and 1/2 in. or 10, 12, and 14 mm Square Shafts
M9220-602	Replacement Locking Clips for ES89/177 Series Floating Electric Spring Return Actuators (Five per Bag)
M9220-603	Adjustable Stop Kit for ES89/177 Series Floating Electric Spring Return Actuators
M9220-604	Replacement Manual Override Cranks for ES89/177 Series Floating Electric Spring Return Actuators (Five per Bag)
M9220-610	Replacement Shaft Gripper, 10 mm Square Shaft with Locking Clip
M9220-612	Replacement Shaft Gripper, 12 mm Square Shaft with Locking Clip
M9220-614	Replacement Shaft Gripper, 14 mm Square Shaft with Locking Clip

1. Furnished with the damper and may be ordered separately.

Mounting

The ES89Ax(-S) Series On/Off Electric Spring Return Actuators can be easily installed on dampers with 1/2 to 3/4 in. or 12 to 19 mm round shafts, or 3/8 and 1/2 in. or 10, 12, and 14 mm square shafts. An M9220-600 Jackshaft Coupler Kit is available for 3/4 to 1-1/16 in. or 19 to 27 mm round shafts, or 5/8 and 3/4 in. or 16, 18, and 19 mm square shafts; see Table 1 for more details. If the damper shaft extends less than 3-19/32 in. (91 mm), see the *Removable Coupler* section for further instructions. If the damper shaft extends less than 1-5/32 in. (29 mm), install an extension recommended by the damper manufacturer.

Counterclockwise (CCW) Spring Return Direction – Clockwise (CW) Powered Operation

For CCW spring return direction, mount the actuator to the damper shaft so that the Side A of the actuator is away from the damper as illustrated in Figure 2. With power applied, the actuator drives CW from the 0° position and spring returns CCW.

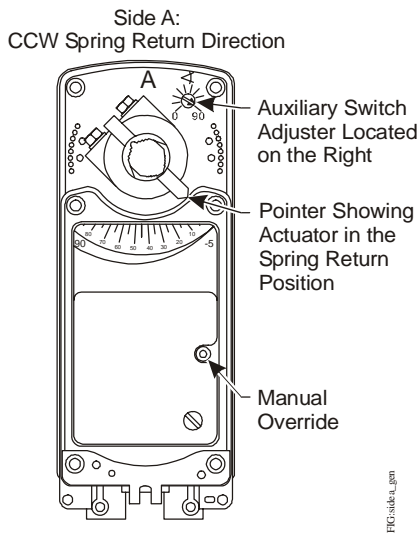

Figure 2: Side A of Actuator

Clockwise (CW) Spring Return Direction – Counterclockwise (CCW) Powered Operation

To change the spring return direction to CW, mount the actuator to the damper shaft so that Side B of the actuator is away from the damper as illustrated in Figure 3. With power applied, the actuator now drives CCW from the 0° position and spring returns CW.

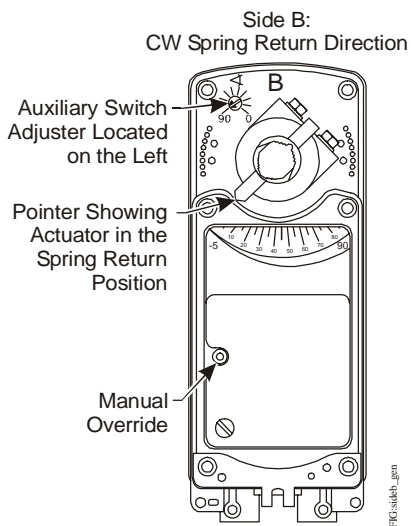

Figure 3: Side B of Actuator

Removable Coupler

The coupler may be installed on either side of the output hub. If the damper shaft is less than 3-19/32 in. (91 mm) long, insert the coupler in the face of the actuator closest to the damper. If the damper shaft is less than 1-5/32 in. (29 mm) long, a shaft extension is required to mount the actuator.

To change the position of the coupler, see Figure 4 and proceed as follows:

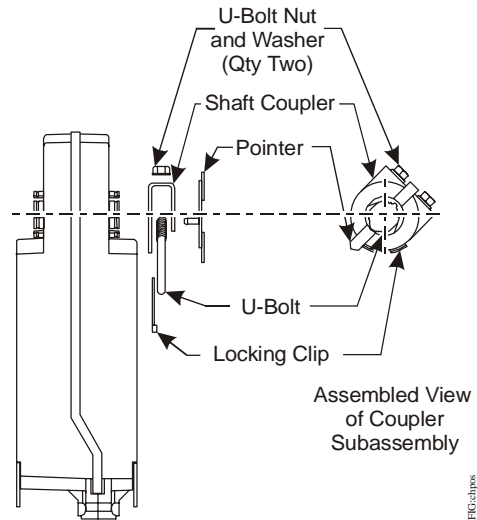

Figure 4: Changing the Position of the Coupler

1. Mount the coupler on either Side A or Side B of the actuator, as determined by the shaft length.
2. Snap the locking clip securely into the coupler retention groove to retain the coupler.

Manual Override

Use only the supplied manual override crank to reposition the actuator hub when using the manual override feature.

IMPORTANT: Applying excessive torque to the manual override or running the manual override with a power tool may damage the internal components of the actuator and cause premature failure.

To reposition the actuator hub, proceed as follows:

1. De-energize the actuator.
2. Insert the hex end of the manual override crank into the manual override adjustment point on the face of the actuator.
3. Rotate the manual override crank in the direction indicated by the arrow on the label.

Note: The actuator requires 27 rotations of the manual override crank from the fully spring return position to fully reposition the actuator hub. At the end of travel, the rotational resistance increases; do not force the actuator hub past this point.

4. Rotate the manual override crank a half turn in the opposite direction to lock the actuator hub in place.

Note: Rotate the manual override crank in the direction indicated by the arrow on the label to unlock the actuator hub. The actuator hub automatically unlocks when power is applied to the actuator and returns the actuator to normal drive and spring return operation.

5. Remove the manual override crank and store it in an unused mounting hole.

Mounting the Actuator

To mount the actuator, proceed as follows:

1. See the dimensions in Figure 5 and Table 2 to ensure the correct positioning of the anti-rotation bracket.

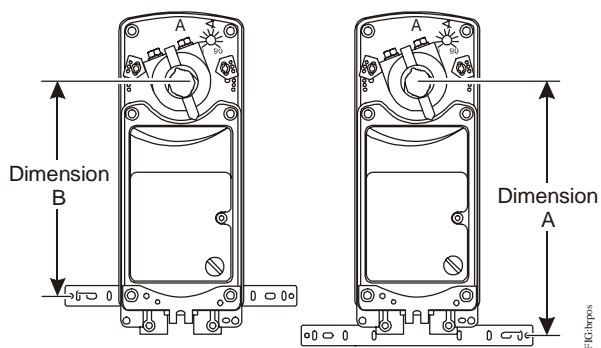

Figure 5: Positioning the Anti-Rotation Bracket

Table 2: Dimensions from Anti-Rotation Bracket to Shaft Center

Shaft Diameter	Dim. A, in. (mm)	Dim. B, in. (mm)
1/2 to 9/16 in. (12 to 14 mm)	8-9/32 (210)	7 (178)
5/8 to 3/4 in. (16 to 19 mm)	8-5/32 (207)	6-29/32 (175)

IMPORTANT: The tab on the anti-rotation bracket must fit midpoint in the actuator slot. Positioning the tab midpoint in the slot prevents actuator binding and premature wear, and makes actuator removal easier.

2. Bend or cut the anti-rotation bracket to fit the damper frame or duct as illustrated in Figure 6.

Note: The anti-rotation bracket can be bent to fit a round damper.

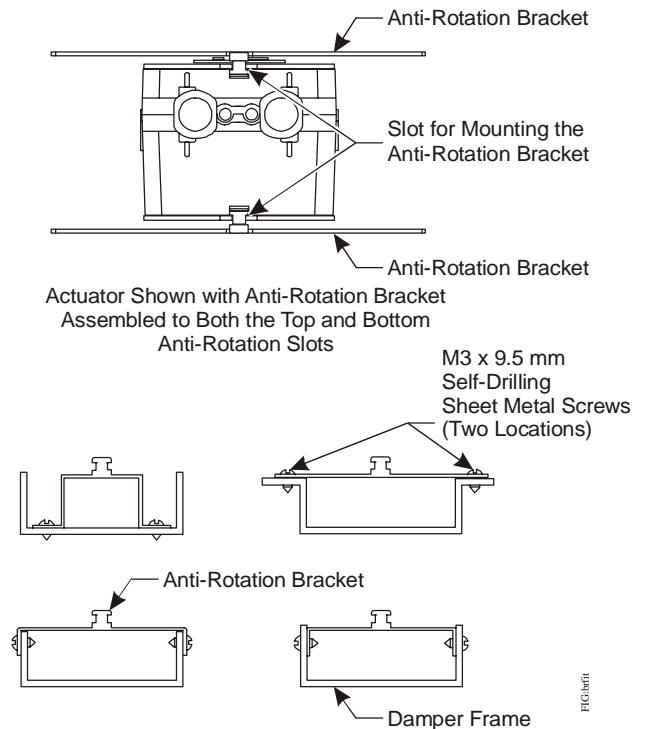

Figure 6: Fitting the Anti-Rotation Bracket on the Damper Frame or Duct

3. Drill mounting holes in the damper frame or duct using the anti-rotation bracket as a guide (based on the measurements obtained in Table 2 and Figure 5).
 4. Secure the anti-rotation bracket to the damper frame or duct using the two M3 x 9.5 mm self-drilling sheet metal screws provided and a 1/4 in. (6 mm) blade screwdriver or 5/16 in. (8 mm) nut driver.
- IMPORTANT:** Do not overtighten the mounting screws to avoid stripping the threads. Be certain that the tab on the anti-rotation bracket remains properly positioned in the slot on the actuator, and that the actuator remains parallel to the mounting surface.
5. Slide the actuator onto the damper shaft, and position the tab of the anti-rotation bracket into the slot at the bottom of the actuator as illustrated in Figure 6.

6. Rotate the damper blade(s) to the desired position if the power is lost. To ensure a tight seal, insert the manual override crank and turn it 5 turns in the direction indicated by the arrow on the label; the position indicator should be near the 0° position on the scale. Quickly rotate the manual override crank a half turn in the opposite direction to temporarily lock the actuator hub in place.
7. Evenly hand tighten each clamp nut onto the U-bolt, keeping the actuator flat. Secure the U-bolt to the damper shaft and tighten to a torque of 100 to 125 lb-in (11 to 14 N·m).
8. To release the spring, turn the manual override crank in the direction indicated on the label; the actuator spring returns to its starting position. If this step is omitted, the spring releases automatically when power is applied to the actuator.
9. Remove the manual override crank and store it in an unused mounting hole.
10. Apply power long enough for the actuator to travel a full stroke, and verify that the actuator rotates freely throughout the range.

Note: If electric power is not available, complete this verification by reinserting the manual override crank and turning it in the direction indicated to rotate the coupler to the fully open position.

Rotation Range using Optional M9220-603 Adjustable Stop Kit

The actuator is factory set for 90° rotation, and its rotation range is limited in 5° increments to a minimum of 30°. Stroke limiting stops are attached in the field to the shaft coupler side of the actuator to reduce the rotation range. Attaching a stroke limiting stop in the farthest mounting position reduces the rotation range of the actuator by 5°. Each progressive mounting position reduces the rotation range an additional 5°.

1. Check that the damper blade is accessible or that its position is permanently marked on the end of the damper shaft as illustrated in Figure 7.

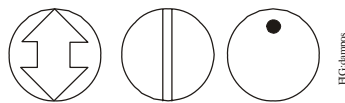

Figure 7: Damper Position Icons

2. Determine the desired rotation range. If a 65 to 90° rotation range is desired, add one stroke limiting stop. If a 35 to 60° rotation range is desired, add two stroke limiting stops.

Note: If two stroke limiting stops are applied, use the manual override crank to position and lock the actuator in a mid-stroke position to gain access to both stroke limiting stop mounting positions.

3. Mount the stroke limiting stop(s) in the desired position using the two M4 x 10 mm self-tapping screws provided. Tighten the screws to a torque of 35 lb-in (4 N·m).
4. Manually reposition the coupler so that the coupler set screw aligns with the nodule guide that corresponds to the value determined in Step 2.

Example:

For a rotation range of 65°, mount one stroke limiting stop in the minimum stroke position as illustrated in Figure 8.

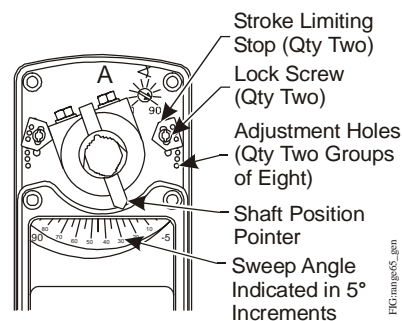

Figure 8: One Stroke Limiting Stop Mounted in the Minimum Stroke Position for a Rotation Range of 65

Wiring

The ES89Ax(-S) Series On/Off Electric Spring Return Actuator provides reliable, integrated damper control. An AC 24 V at 50/60 Hz or DC 24 V input signal (ES89A2[-S] Series models) between the black and red wires, or an AC 120 V input signal at 60 Hz (ES89A1[-S] Series models) between the black and white wires, causes the output hub to rotate from -5 to 90° (unless an external mechanical limit is reached).

Once the command to rotate is removed, the actuator holds its position, until either another command to rotate is applied or until all power is removed. When power is removed, the actuator spring returns to its -5° position (unless an external mechanical limit is reached). A stall condition while driving between -5 to 90° causes the output hub to stop motion and hold its position until power is removed. Rotation is mechanically limited to the -5 and 90° positions by integral end-stops. Optional end-stops are available to limit the output hub travel. An anti-rotation bracket prevents rotational movement of the actuator body.

See Figure 9 and Figure 10 for proper wiring of the ES89Ax(-S) Series On/Off Electric Spring Return Actuator.

CAUTION: Risk of Electric Shock.
Disconnect the power supply before making electrical connections to avoid electric shock.

CAUTION: Risk of Property Damage.
Do not apply power to the system before checking all wiring connections. Short circuited or improperly connected wires may result in permanent damage to the equipment.

IMPORTANT: Make all wiring connections in accordance with local, national, and regional regulations. Do not exceed the electrical ratings of the ES89Ax(-S) Series On/Off Electric Spring Return Actuator.

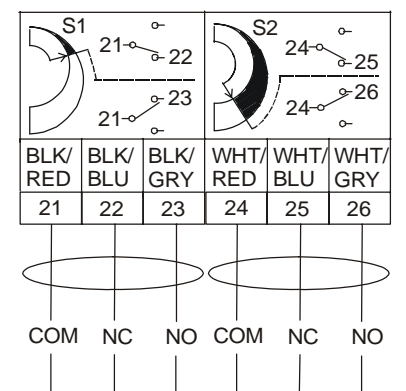

Figure 9: Auxiliary Switch Wiring Diagram for ES89Ax-S Series Models

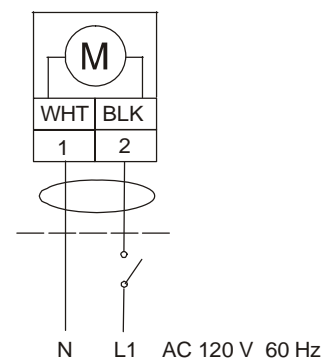
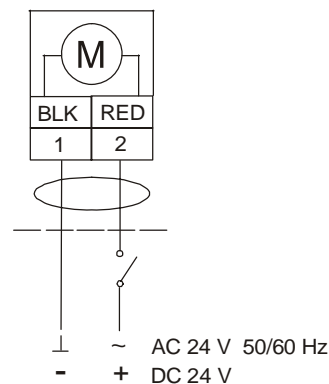

Figure 10: Control Wiring Diagrams

Auxiliary Switches (ES89Ax-S Series Models)

The ES89Ax-S Series models include two integral auxiliary switches with a switch adjuster accessible on either face of the actuator (as illustrated in Figure 2 and Figure 3). The nominal factory setting for auxiliary switch No. 1 is 11° closing, and the nominal factory setting for auxiliary switch No. 2 is 81° opening (relative to a 0 to 90° rotation range). See the [Technical Specifications](#) table for the auxiliary switch ratings.

WARNING: Risk of Electric Shock.
Disconnect each of multiple power supplies before making electrical connections. More than one disconnect may be required to completely de-energize equipment. Contact with components carrying hazardous voltage can cause electric shock and may result in severe personal injury or death.

The switch point of auxiliary switch No. 1 is fixed. The switch point of auxiliary switch No. 2 is independently and continuously adjustable from 25 to 95°. See Figure 11 and use the method in the following steps for the most accurate positioning of auxiliary switch No. 2.

To change the switch point of auxiliary switch No. 2, proceed as follows:

1. Position the actuator in the full spring return position.

Note: Auxiliary switch No. 2 is factory set to trip when the actuator reaches the 81° position.

2. Rotate the switch adjuster until it points to the desired switch point.

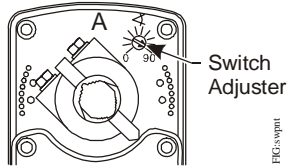

Figure 11: Switch Point Settings

3. Connect auxiliary switch No. 2 to a power source or an ohmmeter, and apply power to the actuator. The actuator moves to the fully open position and holds while power is applied.
4. Observe the switch point. If required, repeat Steps 2 and 3.

Technical Specifications

ES89Ax(-S) Series On/Off Electric Spring Return Actuators (Part 1 of 2)

Power Requirements	ES89A2(-S) Series Models	AC 24 V (AC 19.2 to 28.8 V) at 50/60 Hz: Class 2 (North America) or Safety Extra-Low Voltage (SELV) (Europe), 17.7 VA Running, 9.3 VA Holding Position; DC 24 V (DC 21.6 V to 26.4 V) Class 2 (North America) or SELV (Europe), 15.6 W Running, 2.6 W Holding Position
	ES89A1(-S) Series Models	AC 120 V (AC 102 to 132 V) at 60 Hz: 0.20 A Running, 0.12 A Holding Position
Auxiliary Switch Rating	ES89Ax-S Series Models	Two Single-Pole, Double-Throw (SPDT), Double-Insulated Switches with Gold Flash Contacts: AC 24 V, 50 VA Pilot Duty; AC 120 V, 5.8 A Resistive, 1/4 hp, 275 VA Pilot Duty; AC 240 V, 5.0 A Resistive, 1/4 hp, 275 VA Pilot Duty
Spring Return		Direction is Selectable with Mounting Position of Actuator: Side A, Actuator Face Away from Damper for CCW Spring Return; Side B, Actuator Face Away from Damper for CW Spring Return
Running and Spring Return Torque		89 lb-in (10 N·m)
Rotation Range		Adjustable from 30 to 90° CW or CCW with Optional M9220-603 Adjustable Stop Kit; Mechanically Limited to 90°
Rotation Time	Power On (Running)	24 to 57 Seconds for 0 to 89 lb-in (0 to 10 N·m) at All Operating Conditions; 35 Seconds Nominal at Full Rated Load
	Power Off (Spring Returning)	11 to 15 Seconds for 0 to 89 lb-in (0 to 10 N·m) at Room Temperature; 35 Seconds Maximum for 0 to 89 lb-in (0 to 10 N·m) at -22°F (-30°C); 130 Seconds Maximum for 0 to 89 lb-in (0 to 10 N·m) at -40°F (-40°C)
Cycles		60,000 Full Stroke Cycles

Repair Information

A number of replacement parts are available; see Table 1 for more details. If the ES89Ax(-S) Series On/Off Electric Spring Return Actuator fails to operate within its specifications, replace the unit. For a replacement electric actuator, contact the nearest Dodge Engineering & Controls representative.

ES89Ax(-S) Series On/Off Electric Spring Return Actuators (Part 2 of 2)

Audible Noise Rating	Power On (Running)	<66 dBA Nominal at 39-13/32 in. (1 m)
	Power On (Holding)	<18 dBA Nominal at 39-13/32 in. (1 m)
	Power Off (Spring Returning)	<66 dBA Nominal at 39-13/32 in. (1 m)
Electrical Connections	Actuator (All Models)	48 in. (1.2 m) Halogen-Free Cable with 18 AWG (0.75 mm ²) Wire Leads
	Auxiliary Switches (ES89Ax[-S] Series Models)	48 in. (1.2 m) Halogen-Free Cable with 18 AWG (0.75 mm ²) Wire Leads
Conduit Connections		Integral Connectors for 3/8 in. Flexible Metal Conduit
Mechanical Connections	Standard Shaft Clamp Included with Actuator	1/2 to 3/4 in. or 12 to 19 mm Diameter Round Shafts, or 3/8 and 1/2 in. or 10, 12, and 14 mm Square Shafts
	Optional M9220-600 Jackshaft Coupler Kit	3/4 to 1-1/16 in. or 19 to 27 mm Diameter Round Shafts, or 5/8 and 3/4 in. or 16, 18, and 19 mm Square Shafts
Aluminum Enclosure		NEMA 2 (IP54) for All Mounting Orientations
Ambient Conditions	Operating	-40 to 131°F (-40 to 55°C); 90% RH Maximum, Noncondensing
	Storage	-85 to 185°F (-65 to 85°C); 95% RH Maximum, Noncondensing
Dimensions		See Figure 1.
Compliance	United States	UL Listed, CCN XAPX, File E191697; to UL 60730-1A: Automatic Electrical Controls for Household and Similar Use; and UL 60730-2-14: Part 2, Particular Requirements for Electric Actuators. (All Models)
	Canada	UL Listed, CCN XAPX7, File E191697; to CAN/CSA-E60730-1: Automatic Electrical Controls for Household and Similar Use. (All Models)
	Europe	CE Mark, EMC Directive 89/336/EEC (ES89A2[-S] Series Models)
		CE Mark, Low Voltage Directive 73/23/EEC (ES89A2-S Models)
	Australia and New Zealand	C-Tick Mark, Australia/NZ Emissions Compliant (ES89A2[-S] Series Models)
Shipping Weight	ES89A1(-S) Series Models	7.6 lb (3.5 kg)
	ES89A2(-S) Series Models	6.4 lb (2.9 kg)

The performance specifications are nominal and conform to acceptable industry standards. For application at conditions beyond these specifications, consult the local Dodge Engineering & Controls office. Dodge Engineering & Controls, Inc. shall not be liable for damages resulting from misapplication or misuse of its products.



**DODGE ENGINEERING
& CONTROLS, INC.**

Dodge Engineering & Controls, Inc.
196 Riverneck Road
Chelmsford, MA 01824

978-244-1200 or 877-DEI-CTRL (Toll Free)
978-244-1422 (Fax)