



## GL Series Linear Metallic Linkage Features (Zone, Low and Medium Torque)

### ◆ Variety of Physical Linkage Body Sizes

- Lower profile zone linkage body fits into small areas

### ◆ All Metal Construction

- Linkage housing is made of extruded aluminum for strength and corrosion resistance
- Oil impregnated bronze bearings allow smooth operation of the actuator drive shaft
- Solid steel internal rack and gear for strength and durability

### ◆ Adjustable Tubular Legs

- Provides a wide adjustable range to complement most globe valves
- Maximum temperature dissipation, less heat transfer to actuators
- Excellent collar to stem alignment

### ◆ Multiple Actuator Bracket Orientation

- Flexible actuator mounting allows for right or left hand mounting and other configurations
- Fits multiple brands of actuators

### ◆ Direct Drive Mounting

- Actuator mounts directly on the linkage drive stem eliminating time-consuming interface pieces

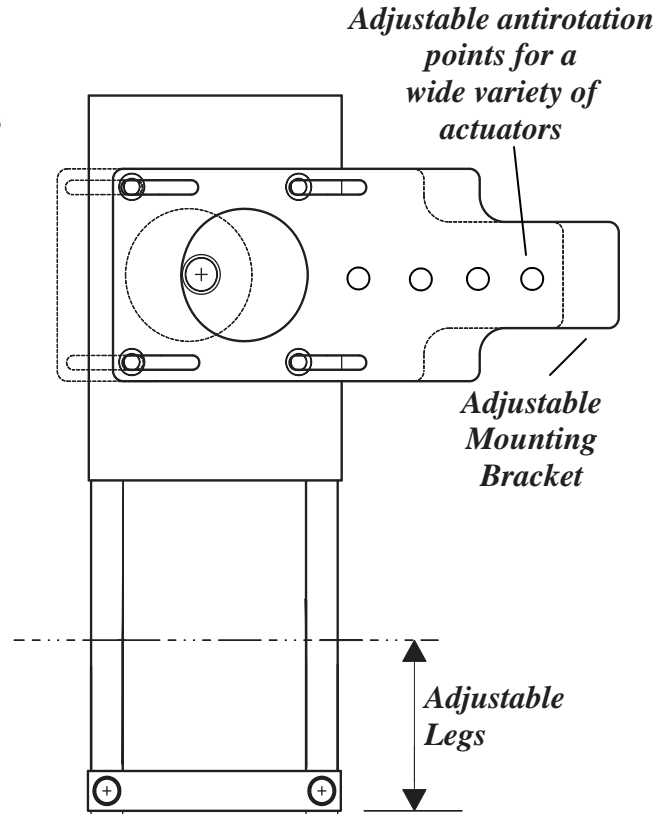

### ◆ High Close-off Capabilities

- Linkages are available for single or dual actuator applications to meet most high close-off requirements

### ◆ Self Alignment Action (patent pending)

- Medium series linkage has internal rotary to linear slide mechanism which moves the valve stem with virtually no side loading. This gives longer valve life on high torque applications



## GL Series Metallic Globe Valve Linkage Specifications

**Made of High Quality, High Strength, All Metal Parts**

### Application

Available for 1/2" to 6" globe valves. Constructed of high strength extruded aluminum alloy, torque tested to over 1200 in-lbs. Dual units are rated for continuous use at 800 in-lbs. Adjustable tubular legs allow use with a wide range of valve stem lengths and allow ease of retrofit on nonstandard valves.

Extra long adjustable legs are available for high temperature applications. Shorter legs are available for some applications with space limitations.

For higher close-off applications dual actuators can be mounted.

Standard mounting hardware is available for most valves made by Barber-Colman (Siebe), Honeywell, Johnson Controls, Landis & Staefa (Siemens) and others. Flexible actuator orientation allows for more field applications than ever before. All mounting hardware is supplied and custom hardware is available upon request.

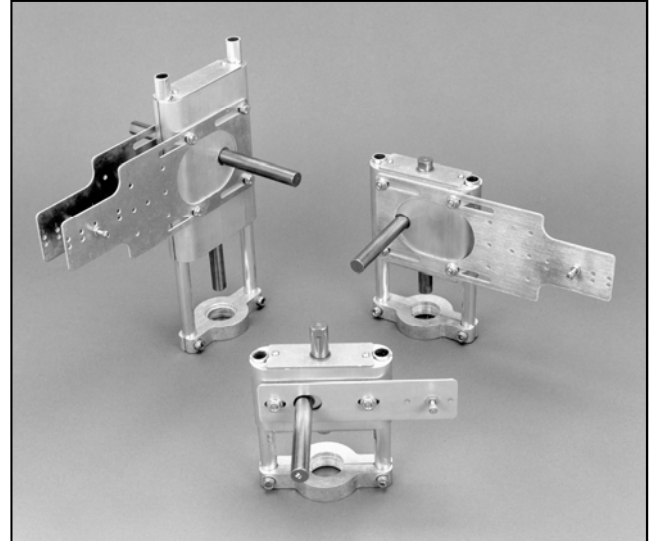

### Operation

The actuator is mounted to the linkage on a direct drive gear shaft. The direct drive internal integral shaft allows for ease of mounting. Manual override handles are available on the non-spring return actuators. The actuator and linkage are provided separately to make assembly easier and to prevent damage to the components during field assembly. The rotary motion of the actuator is transmitted through the shaft to the gear rack assembly. This converts the rotary motion of the actuator to a linear movement at the valve operating rod. The current limiting function built into the actuator provides consistent close-off of the valve, equivalent to the actuator's full torque rating. See actuator/valve close-off rating charts, GVR-8-11.

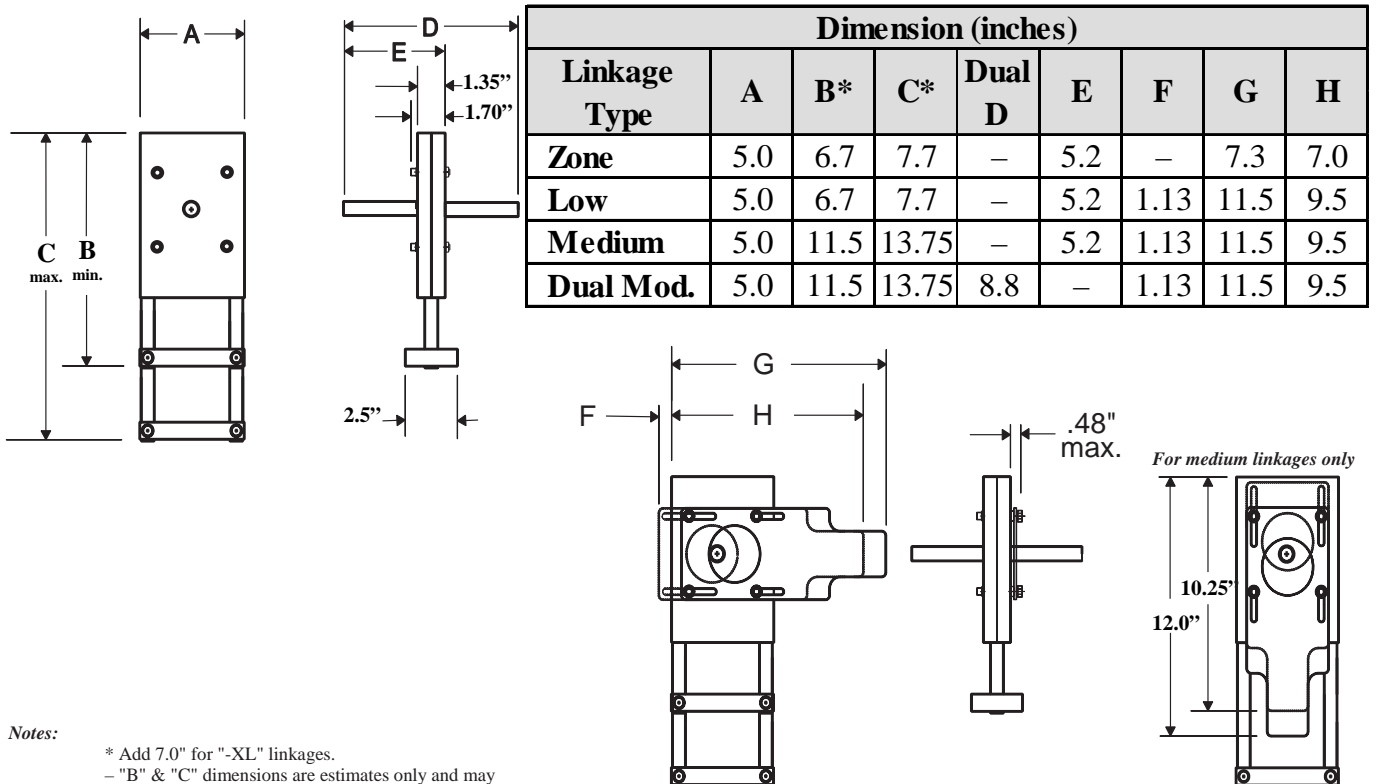

Notes:

- \* Add 7.0" for "-XL" linkages.
- "B" & "C" dimensions are estimates only and may vary depending on valve manufacturer, size, and how it is assembled.



## Determining Linkage Selection for Ordering

- 1) Select linkage stroke, collar type and thread size from chart on page GVR-5 or 6 according to what valve body the linkage is to be mounted on.
- 2) Add "-XL" if steam inlet pressure is 30 PSI or greater or water temperature is 270°F or greater (linkage will be provided with extra long legs).
- 3) Select actuator required by referring to the *Actuator Selection Chart* on page GVR-7.
- 4) Double check close-off of actuator on valve using *Valve Size and Valve Lift Chart* on pages GVR-7 through GVR-12.
- 5) Once a specific actuator is selected, choose the linkage style according to *Linkage Style Chart* on page GVR-12.

### *Example*

Retrofitting Siemens Series 599, Two-Way 1/2" globe valve with non-spring return, modulating actuator:

- |   |                                     |
|---|-------------------------------------|
| 1) Select "20L4A6" (see bold text on page GVR-6)  | Part # Development<br>___/___20L4A6 |
| 2) Not high temperature, "-XL" not required   | ___/___20L4A6                       |
| 3) Select EN44B2  | EN44B2/___20L4A6                    |
| 4) Note the close-off for EN44 3/4" lift (20mm) is 165 PSI (see GVR-8)                  | EN44B2/___20L4A6                    |
| 5) Select GLZ0B by referencing actuator code & stroke<br>(EN44 and 3/4" on page GVR-12) | EN44B2/GLZ0B20L4A6                  |

Please call customer support at DEI if you have any questions. Once you become familiar with this process it becomes quite simple. (If the valve you are retrofitting is not listed, please call DEI).



## GL Series Metallic Linkage Part Number Description

### How to Order a Linkage:

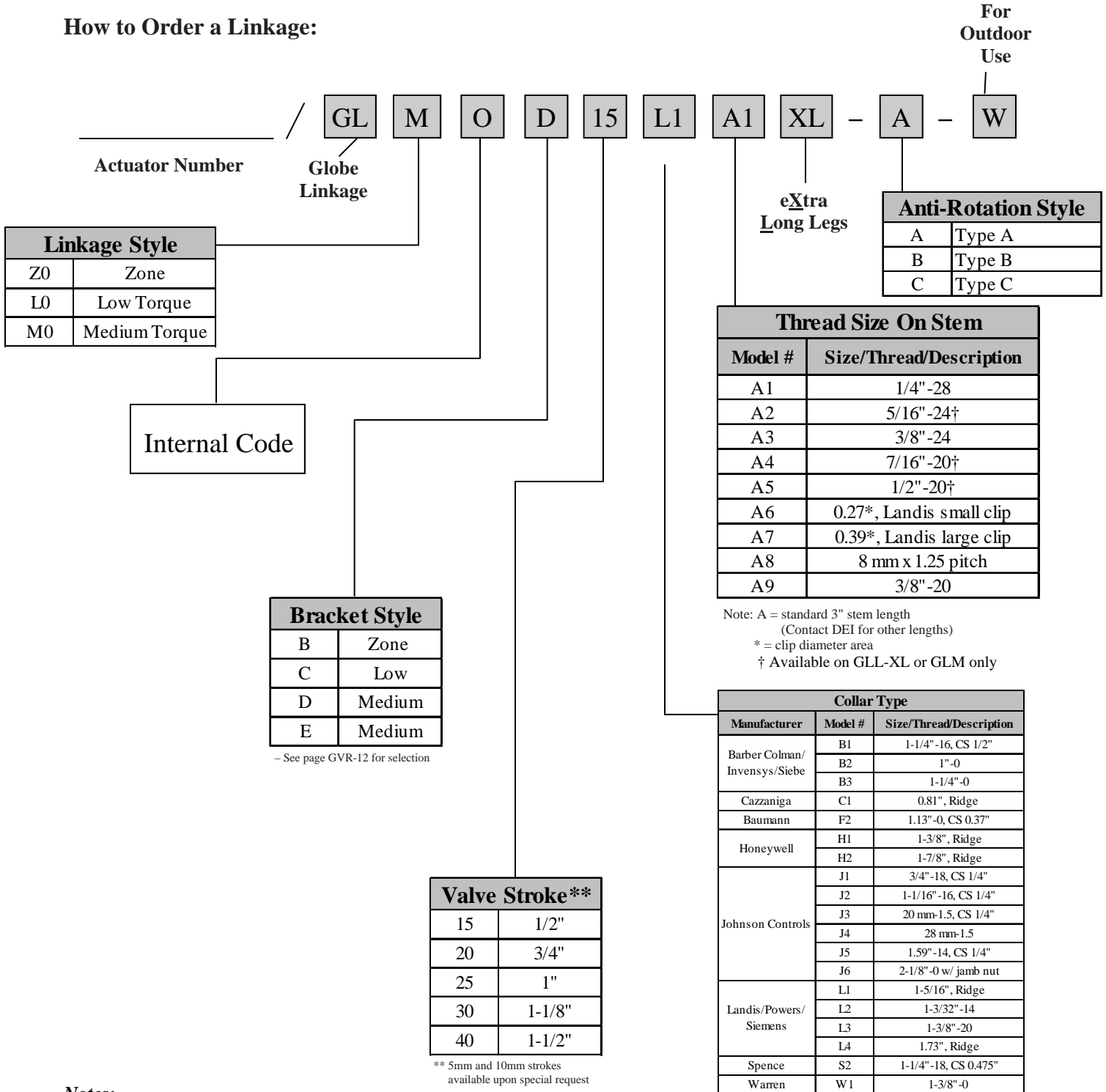

**Notes:**

- "0" = straight bore through.
- "CS" = counter sunk for packing nut.
- Customs available upon request.



## Globe Valve Metallic Retrofit Linkage Selection Chart

### 1/2" to 6" Valves

#### (Stroke, Collar Type & Stem Size)

Metallic Linkage Part Number and Close-off Rating*												
Valve Body		Valve Size										
Manufacturer	Model #	1/2"	3/4"	1"	1-1/4"	1-1/2"	2"	2-1/2"	3"	4"	5"	6"
Honeywell	V5011, V5013	20H1A1	20H1A1	20H1A1	20H1A1	20H1A1	20H1A1	20H1A1	20H1A1	40H2A4	40H2A4	40H2A4
Siebe* (Barber Colman) (Invensys)	VB-111-0-X-1 thru 9	15B1A1	15B1A1	15B1A1	15B1A1	-	-	-	-	-	-	-
	VB-921X-0-X-1 thru 13	15B1A1	15B1A1	15B1A1	15B1A1	25B2A1	25B2A1	25B3A5	40B3A5	-	-	-
	VB-922X-9-X-1 thru 13	15B1A1	15B1A1	15B1A1	15B1A1	25B2A1	25B2A1	25B3A5	25B3A5	-	-	-
	VB-925X-0-X-1 thru 13	15B1A1	15B1A1	15B1A1	15B1A1	25B2A1	25B2A1	25B3A5	25B3A5	-	-	-
	VB-926X-0-X-1 thru 13	15B1A1	15B1A1	15B1A1	15B1A1	25B2A1	25B2A1	25B3A5	25B3A5	-	-	-
	VB-928X-0-X-1 thru 11, VB-927X-0-X-1 thru 11	15B1A1	15B1A1	15B1A1	15B1A1	25B2A1	25B2A1	-	-	-	-	-
	VB-931X-0-X-1 thru 14	15B1A1	15B1A1	15B1A1	15B1A1	25B2A1	25B2A1	25B3A5	25B3A5	40B3A5**	-	-
	VB-932X-0-X-1 thru 11	15B1A1	15B1A1	15B1A1	15B1A1	25B2A1	25B2A1	20W1A3	20W1A3	25W1A3	30W1A3	40W1A3
	VB-7213, VB-7313, VB-7253, VB-7273	15B1A1	15B1A1	15B1A1	15B1A1	15B1A1	15B1A1	-	-	-	-	-

**Notes:**

- Linkage part numbers subject to manufacturer changes without notice. To ensure shipment of correct parts please fill out Valve Dimension Worksheet (GVR-13).
- If no information is found on the chart, please fill out the Valve Dimension Worksheet (GVR-13) to see if linkage is available standard or custom (1-1/2" lift is maximum available).

**Warning:**

- \* Stroke on valve should be confirmed before ordering linkage for 1-1/2" to 6" size valves. Approximately 20 years ago Barber Colman changed stroke lengths, but not valve body numbers. Unfortunately date code of change is not available.
- \*\* 4"-6" valves had another stroke change more recently. Please confirm measurements.



## Globe Valve Metallic Retrofit Linkage Selection Chart

### 1/2" to 6" Valves

#### (Stroke, Collar Type & Stem Size)

Metallic Linkage Part Number and Close-off Rating*												
Valve Body		Valve Size										
Manufacturer	Model #	1/2"	3/4"	1"	1-1/4"	1-1/2"	2"	2-1/2"	3"	4"	5"	6"
Johnson Controls	V90AD-1C thru 7C V90DD-1C thru 7C	15J1A1	15J1A1	20J1A1	-	20J1A1	-	-	-	-	-	-
	V90CA-1 thru 8	20J1A1	20J1A1	20J1A1	20J1A1	20J1A1	20J1A1	20J2A3	30J2A3	-	-	-
	VG Series	15J3A*	15J3A*	15J4A*	15J4A*	15J4A*	15J4A*	20J6A3	30J6A3	30J6A3	40J6A5	40J6A5
	VTM Series, ** VB-3752	15J1A1	15J1A1	15J1A1	15J1A1	20J1A1	20J1A1	20J2A3	20J2A3	30J2A3	40J5A5	40J5A5
	VB-3754-1 thru 8 VB-3970	15J1A1	15J1A1	20J1A1	20J1A1	20J1A1	20J1A1	20J2A3	30J2A3	30J2A3	40J5A5	40J5A5
	VB-3974-1 thru 7 VB-4324-1 thru 7, VB-4322	15J1A1	15J1A1	20J1A1	20J1A1	20J1A1	20J1A1	20J2A3	30J2A3	30J2A3	40J5A5	40J5A5
	V-5462	-	-	-	-	-	-	20J5A3	30J5A3	30J5A5	40J5A5	40J5A5
Siemens (Landis) (Powers)	590 (Three-way)	-	-	-	-	15L2A1	15L2A1	20L3A3	20L3A3	25L3A3	40L3A3	40L3A3
	591 (Two-way)	-	-	-	-	25L2A1	25L2A1	20L3A3	20L3A3	25L3A3	40L3A3	40L3A3
	658 ("Powers" on Body)	15L1A1	15L1A1	15L1A1	15L1A1	-	-	-	-	-	-	-
	599	<b>20L4A6</b>	20L4A6	20L4A6	20L4A6	20L4A6	20L4A6	20L4A6	20L4A6	20L4A7	20L4A7	20L4A7
Cazzaniga	V2BM	20C1A8	20C1A8	20C1A8	20C1A8	20C1A8	20C1A8	-	-	-	-	-
	V3BM	20C1A8	20C1A8	20C1A8	20C1A8	20C1A8	20C1A8	-	-	-	-	-

**Notes:**

- \* For "T" stems use A1. For "L" or "M" stems use A9.
- \*\* With screwed stems and bonnets.
  - Linkage part numbers subject to manufacturer changes without notice. To ensure shipment of correct parts please fill out Valve Dimension Worksheet (GVR-13).
  - If no information is found on the chart, please fill out the Valve Dimension Worksheet (GVR-13) to see if linkage is available standard or custom (1-1/2" lift is maximum available).



## Actuator Close-Off Chart

Type A Actuator Type	Valve Size											
	1/2"	3/4"	1"	1-1/4"	1-1/2"	2"	2-1/2"	3"	4"	5"	6"	
Spring Return	ES62 (62 in-lb)											
	ES142 (142 in-lb)											
							Dual ES142 (284 in-lb)					
Non-Spring Return	EN44 (44 in-lb)								Dual EN310 (620 in-lb)			
	EN88 (88 in-lb)											
	EN132 or EN221 (132 or 221 in-lb)											
					EN310 (310 in-lb)							

*Note:* See pages GVR-8-11 for close-off pressures.

Type B Actuator Type	Valve Size											
	1/2"	3/4"	1"	1-1/4"	1-1/2"	2"	2-1/2"	3"	4"	5"	6"	
Spring Return	ES52 or ES53 or ES89 (52 or 53 or 89 in-lb)											
	ES177 (177 in-lb)											
							Dual ES177 (354 in-lb)					
Non-Spring Return	EN53 (53 in-lb)								Dual EN210 (420 in-lb)			
	EN70 or ES70 (70 in-lb)											
	EN140 (140 in-lb)											
					EN210 or EN280 (210 or 280 in-lb)							

*Note:* See pages GVR-8-11 for close-off pressures.



## Actuator Close-off Chart

### 35 in-lb Actuators (EN35) Close-off Pressure

Valve Size	Nominal Close-off Pressure in PSI*		
	1/2" Lift (15mm)	3/4" Lift (20mm)	1" Lift (25mm)
1/2"	>250	216	186
3/4"	131	102	85
1"	77	57	47
1-1/4"	48	36	30

### 44 in-lb Actuators (EN44) Close-off Pressure

Valve Size	Nominal Close-off Pressure in PSI*		
	1/2" Lift (15mm)	3/4" Lift (20mm)	1" Lift (25mm)
1/2"	>250	>250	234
3/4"	165	130	112
1"	96	76	66
1-1/4"	63	50	43

### 52/53 in-lb Actuators (EN53, ES52, ES53) Close-off Pressure

Valve Size	Nominal Close-off Pressure in PSI*		
	1/2" Lift (15mm)	3/4" Lift (20mm)	1" Lift (25mm)
1/2"	>250	>250	>250
3/4"	198	157	135
1"	116	92	79
1-1/4"	76	60	52
1-1/2"	54	42	37
2"	31	24	21

### 62 in-lb Actuators (ES62) Close-off Pressure

Valve Size	Nominal Close-off Pressure in PSI*		
	1/2" Lift (15mm)	3/4" Lift (20mm)	1" Lift (25mm)
1/2"	>250	>250	>250
3/4"	224	174	145
1"	131	98	81
1-1/4"	82	62	51
1-1/2"	57	44	36
2"	32	25	20

**Note:**

\* Close-off listed is an estimated figure for all commercial manufacturers.  
 For specific close-off, valve port opening size and force curves are required. This information is strongly recommended for industrial valves or valves with ANSI class IV leakage ratings.





## Actuator Close-off Chart

### 70 in-lb Actuators (EN70, ES70) Close-off Pressure

Valve Size	Nominal Close-off Pressure in PSI*		
	1/2" Lift (15mm)	3/4" Lift (20mm)	1" Lift (25mm)
1/2"	>250	>250	>250
3/4"	>250	207	179
1"	153	121	104
1-1/4"	100	79	68
1-1/2"	71	56	48
2"	41	32	28

### 88 in-lb Actuators (EN88, ES89) Close-off Pressure

Valve Size	Nominal Close-off Pressure in PSI*		
	1/2" Lift (15mm)	3/4" Lift (20mm)	1" Lift (25mm)
1/2"	>250	>250	>250
3/4"	>250	>250	211
1"	191	142	118
1-1/4"	120	91	75
1-1/2"	83	64	52
2"	46	36	29

### 132 in-lb Actuators (EN132) Close-off Pressure

Valve Size	Nominal Close-off Pressure in PSI*				
	1/2" Lift (15mm)	3/4" Lift (20mm)	1" Lift (25mm)	1-1/8" Lift (30mm)	1-1/2" Lift (40mm)
1/2"	>250	>250	>250	-	-
3/4"	>250	>250	>250	-	-
1"	>250	214	177	166	127
1-1/4"	181	137	112	109	83
1-1/2"	124	96	79	77	58
2"	70	52	44	44	33
2-1/2"	-	39	34	28	21

### 140 in-lb Actuators (ES142, EN140) Close-off Pressure

Valve Size	Nominal Close-off Pressure in PSI*				
	1/2" Lift (15mm)	3/4" Lift (20mm)	1" Lift (25mm)	1-1/8" Lift (30mm)	1-1/2" Lift (40mm)
1/2"	>250	>250	>250	>250	>250
3/4"	>250	>250	>250	>250	231
1"	>250	242	209	177	135
1-1/4"	201	158	137	116	89
1-1/2"	142	112	97	82	62
2"	81	64	55	47	36
2-1/2"	-	42	36	30	23
3"	-	29	25	21	16

**Note:**

\* Close-off listed is an estimated figure for all commercial manufacturers.

For specific close-off, valve port opening size and force curves are required. This information is strongly recommended for industrial valves or valves with ANSI class IV leakage ratings.



## Actuator Close-off Chart

### 177 in-lb Actuators (ES177) Close-off Pressure

Valve Size	Nominal Close-off Pressure in PSI*			
	3/4" Lift (20mm)	1" Lift (25mm)	1-1/8" Lift (30mm)	1-1/2" Lift (40mm)
1"	>250	>250	223	171
1-1/4"	200	173	146	112
1-1/2"	141	122	103	79
2"	81	70	59	45
2-1/2"	53	45	38	29
3"	37	32	27	21

### 210 in-lb Actuators (EN210/EN221) Close-off Pressure

Valve Size	Nominal Close-off Pressure in PSI*			
	3/4" Lift (20mm)	1" Lift (25mm)	1-1/8" Lift (30mm)	1-1/2" Lift (40mm)
1"	>250	>250	–	–
1-1/4"	238	205	–	–
1-1/2"	168	145	–	–
2"	96	83	–	–
2-1/2"	62	54	46	35
3"	44	38	32	24

### 310 in-lb Actuators (EN310) Close-off Pressure

Valve Size	Nominal Close-off Pressure in PSI*			
	3/4" Lift (20mm)	1" Lift (25mm)	1-1/8" Lift (30mm)	1-1/2" Lift (40mm)
2"	142	123	104	79
2-1/2"	92	79	67	51
3"	64	56	47	36
4"	37	32	27	20
5"	24	20	17	13
6"	16	14	12	9

## Dual Actuators

### 280 in-lb Actuators (Single EN280, Dual ES142, Dual EN140) Close-off Pressure

Valve Size	Nominal Close-off Pressure in PSI*			
	3/4" Lift (20mm)	1" Lift (25mm)	1-1/8" Lift (30mm)	1-1/2" Lift (40mm)
2"	128	110	94	72
2-1/2"	84	72	60	46
3"	58	50	42	32
4"	28	24	22	18
5"	18	16	13	11
6"	12	10	9	8

**Note:**

\* Close-off listed is an estimated figure for all commercial manufacturers.

For specific close-off, valve port opening size and force curves are required. This information is strongly recommended for industrial valves or valves with ANSI class IV leakage ratings.



## Actuator Close-off Chart

### Dual Actuators cont.

#### 354 in-lb Actuators (Dual ES177) Close-off Pressure

Valve Size	Nominal Close-off Pressure in PSI*			
	3/4" Lift (20mm)	1" Lift (25mm)	1-1/8" Lift (30mm)	1-1/2" Lift (40mm)
2"	107	139	119	90
2-1/2"	101	76	76	58
3"	73	53	53	40
4"	35	30	28	23
5"	23	20	16	14
6"	15	13	11	10

#### 420 in-lb Actuators (Dual EN210) Close-off Pressure

Valve Size	Nominal Close-off Pressure in PSI*			
	3/4" Lift (20mm)	1" Lift (25mm)	1-1/8" Lift (30mm)	1-1/2" Lift (40mm)
2"	>125	>125	100	76
2-1/2"	120	91	85	63
3"	78	63	58	44
4"	42	36	33	28
5"	26	23	20	17
6"	18	15	14	12

#### 560 in-lb Actuators (Dual EN280) Close-off Pressure

Valve Size	Nominal Close-off Pressure in PSI*			
	3/4" Lift (20mm)	1" Lift (25mm)	1-1/8" Lift (30mm)	1-1/2" Lift (40mm)
2-1/2"	>125	121	113	83
3"	103	83	77	58
4"	55	47	43	37
5"	34	30	26	22
6"	23	19	18	15

#### 620 in-lb Actuators (Dual EN310) Close-off Pressure

Valve Size	Nominal Close-off Pressure in PSI*			
	3/4" Lift (20mm)	1" Lift (25mm)	1-1/8" Lift (30mm)	1-1/2" Lift (40mm)
2-1/2"	>125	>125	125	93
3"	115	93	86	61
4"	63	53	49	41
5"	39	35	30	26
6"	28	23	21	18

**Note:**

\* Close-off listed is an estimated figure for all commercial manufacturers.

For specific close-off, valve port opening size and force curves are required. This information is strongly recommended for industrial valves or valves with ANSI class IV leakage ratings.



## Linkage Style (Zone, Low & Medium Torque)

New Part # (prefix)	Stroke (mm)	Stroke (inches)	Acceptable Actuators*		Old Part # Cross Reference	Max Torque Allowed (in-lb)
			Type A	Type B		
GLZ0B**	15 20	1/2" 3/4"	EN44 EN88	EN35	NVB series 100 & 200	90
GLLOC**	15 20	1/2" 3/4"	EN132 ES62* ES142	EN53, ES52/53* ES/EN70* ES89 * EN140 ES177	NVB series 300 & 400	200
GLM0C	25	1"	EN132 ES62* ES142	EN70* ES89 ES/EN140 ES177	NVB series 300 & 400	200
GLM0D	20 25 30 40	3/4" 1" 1-1/8" 1-1/2"	EN221 EN310 ES142	EN140 EN210 EN280 ES177	LVB series 200, 300, 500	800
GLM0E	20 25 30 40	3/4" 1" 1-1/8" 1-1/2"	Dual EN310 Dual ES142	Dual EN210 Dual EN280 Dual ES140 Dual ES177	LVB series 400 & 600	800

**Notes:**

- When ordering, provide actuator model number being mounted on linkage to ensure proper anti-rotation tab.
- For steam applications with 30 PSI inlet pressure or greater add "-XL" at the end of the part number.
- \* Due to physical size of actuators.
- \*\* Linkage not appropriate for use with Nema 4 Type enclosure. Select a GLM series linkage.

**Caution:** For outdoor or moist applications, GLM linkages must be used and are specially modified. Please make note on purchase order if they are being used for this application by indicating a "-W" after the part number.



# Valve Dimension Worksheet for Actuator Retrofits

This worksheet is for valve linkage selection of non-listed valve types. Make photocopies of this worksheet as needed and fax to DEI.

Choose the figure that most resembles your valve assembly.

FIG. 1

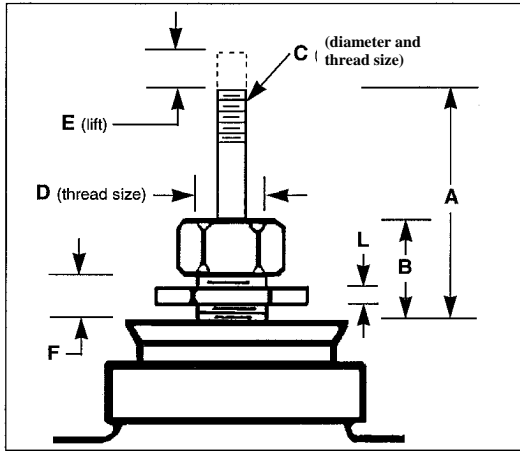

Note: A = Height with stem down  
C = Stem diameter  
D = Major diameter of thread  
E = Lift (Stem up)  
G = Packing nut diameter (tip to tip)  
L = Jam nut

FIG. 2

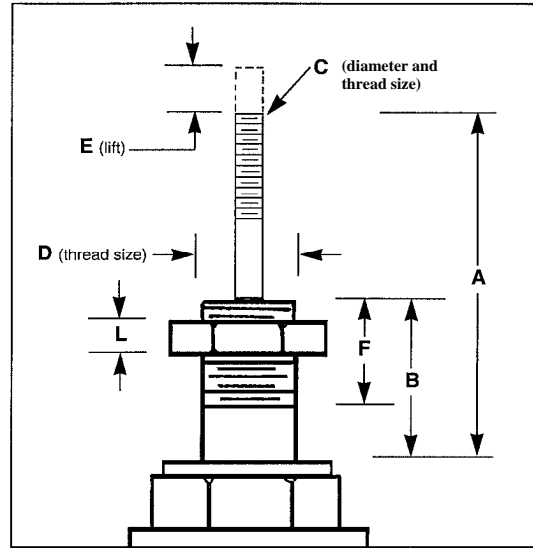

FIG. 3

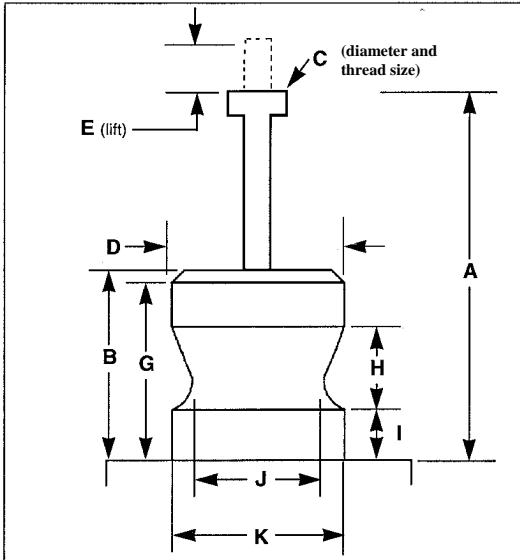

FIG. 4

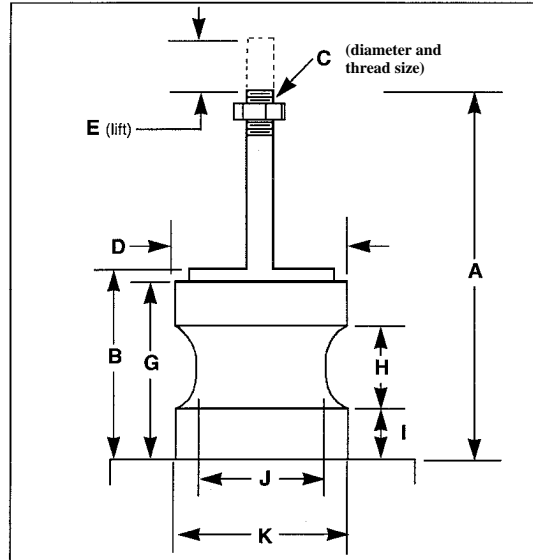

FIG. NO. \_\_\_\_\_

VALVE BODY

Manufacturer \_\_\_\_\_

Model No. \_\_\_\_\_

Valve Size: \_\_\_\_\_

Number of threads per inch (stem) \_\_\_\_\_

2 way or  3 way

COMMENTS

\_\_\_\_\_  
\_\_\_\_\_

**DIMENSIONS**

A = \_\_\_\_\_ B = \_\_\_\_\_

C = \_\_\_\_\_ D = \_\_\_\_\_

E = \_\_\_\_\_ F = \_\_\_\_\_

G = \_\_\_\_\_ H = \_\_\_\_\_

I = \_\_\_\_\_ J = \_\_\_\_\_

K = \_\_\_\_\_ L = \_\_\_\_\_

A separate form should be used for each valve that has different sizing or manufacturer. Please fill out form completely. Redraw if applicable.



## Electronic Globe Valve Retrofits

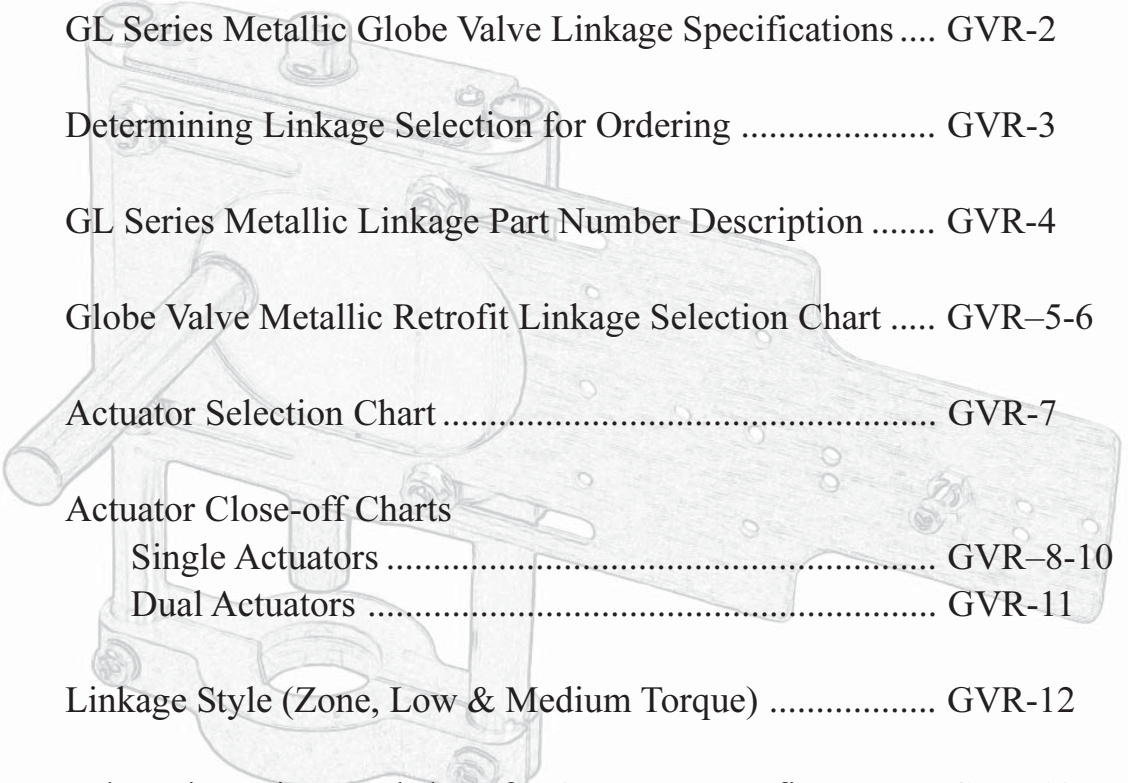

GL Series Linear Metallic Linkage Features .....	GVR-1
GL Series Metallic Globe Valve Linkage Specifications ....	GVR-2
Determining Linkage Selection for Ordering .....	GVR-3
GL Series Metallic Linkage Part Number Description .....	GVR-4
Globe Valve Metallic Retrofit Linkage Selection Chart ....	GVR-5-6
Actuator Selection Chart .....	GVR-7
Actuator Close-off Charts	
Single Actuators .....	GVR-8-10
Dual Actuators .....	GVR-11
Linkage Style (Zone, Low & Medium Torque) .....	GVR-12
Valve Dimension Worksheet for Actuator Retrofits .....	GVR-13